



PRINCE ALBERT MUNICIPALITY

Invitation to Quote

Quotation number: **RFQ 181 / 2025**
Quotation description: **APPOINTMENT OF A SPECIALIZED SERVICE PROVIDER FOR THE ASSESSMENT, REPLACEMENT AND MAINTENANCE OF PUMPS AND MOTORS AT PRINCE ALBERT MUNICIPALITY'S WATER AND TREATMENT PLANTS AND PUMP STATIONS**
Closing date & time: **18 NOVEMBER 2025 @ 12H00**

Prince Albert Municipality hereby invites formal written quotations for the **APPOINTMENT OF A SPECIALIZED SERVICE PROVIDER FOR THE ASSESSMENT , AND REPLACEMENT AND MAINTENANCE OF PUMPS AND MOTORS AT PRINCE ALBERT MUNICIPALITY'S WATER AND TREATMENT PLANTS AND PUMPSTATIONS**. Quotation documents are available at no charge from the Prince Albert Municipality Website at www.pamun.gov.za (Website navigation is as follow: Procurement, Tenders available).

Alternatively, a set of quotation documents can be obtained from Ms. Tamara Qhayi (Finance Division, Thusong Centre, Prince Albert, 6930) during office hours (Monday-Thursday, 07h30 to 16h00) and Friday (07h30 to 15h30) at a non-refundable cost of R 150.00 (VAT Included), payable in cash at the cashiers at the Prince Albert Municipality's Finance Division or via EFT deposit in favour of the Prince Albert Municipality ABSA Bank, Account number 2640-5600-64 Reference: RFQ 181/2025 and company name.

Bids must remain valid for a period of ninety (90) days after the closing date of the bid. Enquiries can be directed as follow:

TYPE OF ENQUIRY	CONTACT PERSON	CONTACT NUMBER	EMAIL ADDRESS
Bidding procedures and quotation documents	Ms. Theolencia Biljohn	023 541 1668	scm@pamun.gov.za
Technical / Specification related Enquiries	Mr. Selwyn Amsterdam	023 541 1036	selwyn@pamun.gov.za

Bidders are required to be registered with the Construction Industry Development Board (CIDB). Only contractors who are registered with the CIDB, in a contractor grading designation to or higher than a contractor grading designation determined in accordance with the sum tendered, or a value determined in accordance with Regulation 25 (1B) or 25 (7A) of the Construction Industry Development Regulations for a **1 ME** or higher class of grading are eligible to have their tenders evaluated.

A **compulsory** clarification meeting will be held as follow:

DATE: **10 November 2025**
VENUE: **Raw Water Reservoirs, Prince Albert, 6930 (GPS coordinates: 33.247064°S 22.037139°E)**
TIME: **10h00**

No bids will be accepted from bidders who did not attend the compulsory clarification meeting. Any bidder arriving late at the clarification meeting will not be permitted to attend the clarification meeting.

This bid is subject to functionality scoring. Bidders must obtain the minimum points for functionality scoring as indicated in the document for the bid to be regarded as responsive. Bids that do not meet the minimum scoring as indicated, will be regarded as non-responsive, and will not be evaluated on price and preference points.

Bids must be submitted in an envelope. The quotation number and quotation title must appear on the outside of the envelope. Bidders that fail to adhere to this requirement, will be disqualified at the bid opening. **Late or unmarked bids will not be considered.**

Bids must be deposited in the tender box at the Finance Division (Thusong Centre, Adderley Street, Prince Albert, 6930). The tender box will be open as follow:

Monday to Thursday: 07h30 and 16h00

Fridays: 07h30 and 15h30.

Telegraphic, telephonic, telex, facsimile, e-mail and late bids will not be accepted.

Bids will be opened in public immediately after the closing date at the Finance Division Boardroom (Finance Building, Thusong Centre). Bids will be evaluated according to the 80/20 preference points system. The bids are subject to the Council's Supply Chain Management Policy, the Municipal Preferential Procurement Policy, and the Preferential Procurement Regulations, 2022 (Government Gazette 47452, dated 04/11/2022). **Tenderers must be registered on the Central Supplier Database (CSD) if they wish to conduct business with the municipality.**

The preferential points system to be applied (80/20) in terms of the Preferential Procurement Policy are as follow:

PRICE	80
B-BBEE STATUS LEVEL OF CONTRIBUTION	10
LOCALITY	10
TOTAL POINTS	100

The Municipality reserves the right to withdraw any invitation to bid and/or re-advertise or to reject any bid or to accept a part of it. The Municipality does not bind itself to accept the lowest bid or to award a contract to the Bidder scoring the highest number of points.

NO BIDS WILL BE CONSIDERED FROM PERSONS IN THE SERVICE OF THE STATE AS DEFINED IN THE MUNICIPAL SUPPLY CHAIN MANAGEMENT REGULATIONS.

ADV. MATTHYS GILIOMEE

Municipal Manager

30 October 2025

BID CONDITIONS AND INSTRUCTIONS

Prince Albert Municipality hereby invites quotations from bidders for the supply of the goods/ services as detailed in the enclosed schedule. The following conditions will apply:

1. GENERAL AND SPECIAL CONDITIONS OF CONTRACT

- 1.1) The General Conditions of Contract (GCC) available on the National Treasury website (<http://www.treasury.gov.za/divisions/ocpo/sc/GeneralConditions/>) will be applicable to this formal written quotation as well as Special Conditions of Contract (SCC) (if applicable) forming part of this set of quotation documents in addition to the conditions and information.
- 1.2) Where the GCC and SCC are in conflict with one another, the stipulations of the SCC will prevail.

2. ACCEPTANCE OR REJECTION OF A QUOTE

- 2.1) The Municipality reserves the right to withdraw any invitation to quote and/or to re-advertise or to reject any quote or to accept a part of it. The Municipality does not bind itself to accepting the lowest quote or the quote scoring the highest points.

3. VALIDITY PERIOD

- 3.1) Bids shall remain valid for the period as contained on the quotation notice.

4. BID DOCUMENTS

- 4.1) The original bid document must be fully completed and **originally signed in black ink** and signed by the authorised signatory to validate the quote. **Bidders are not allowed to complete the documents by re-typing responses – all documents to be completed in black ink and handwritten. Failure to comply will invalidate your offer.**
- 4.2) The complete original bid document must be returned. Missing pages will result in the disqualification of the quotation.
- 4.3) No unauthorised alteration of this set of bid documents will be allowed. Any unauthorised alteration will disqualify the quotation automatically. Any ambiguity has to be cleared with contact person for the quotation before the quotation closure.
- 4.4) The bid document as provided by the Municipality's Supply Chain Management Section will be the prevailing document in the event of an inconsistency between the completed submitted bid document by a bidder and the bid quotation document provided by the Municipality.

5. MUNICIPAL RATES, TAXES AND CHARGES

- 5.1) A copy of the bidder's and those of its director's/members municipal accounts (for the Municipality where the bidder and its director's/members pay their account) for the month preceding the quotation closure date must accompany the bid documents. If such a copy does not accompany the bid document of the successful

bidder, the Municipality reserves the right to obtain such documents after the closing date to verify that their municipal accounts are in order.

- 5.2) Any bidder which is or whose directors are in arrears with their municipal rates and taxes or municipal charges due to any Municipality or any of its entities for more than three months and have not made an arrangement for settlement of same before the bid closure date will be unsuccessful. The arrangement for settlement for the outstanding amount (which were done before the closing date of the bid), must also be submitted with the bid document.
- 5.3) If a bidder and its director's/members rent their premises, the current lease agreement must be submitted with the bid document, which indicates that the rental includes their municipal rates and taxes. If the lease agreement indicates that the bidder or its director's/members are responsible to pay the municipal rates and taxes, the Municipal Account of the address indicated must also be submitted.
- 5.4) If a bidder and its director's/members, do not own any property, they must submit the following:
- (i) Affidavit from the bidder and its director's/members, that they do not own any property;
 - (ii) Affidavit from the owner of the property where business is situated/director's/members reside, that the bidder and its director's/members are not liable for the municipal rates and taxes.
- 5.5) If a bidder and its director's/members, lives outside of South Africa, an affidavit must be submitted.
- 5.6) If a bidder or its director's/members, lives outside of South Africa, an affidavit must be submitted by the Company.

6. AUTHORISED SIGNATORY

- 6.1) **A copy of the recorded Resolution taken by the Board of Directors, members, partners or trustees authorising the representative to submit this bid on the bidder's behalf must be attached to the Bid Document on submission of same.**
- 6.2) A bid shall be eligible for consideration only if it bears the signature of the bidder or of some person duly and lawfully authorised to sign it for and on behalf of the bidder.
- 6.3) If such a copy of the Resolution does not accompany the bid document of the successful bidder, the Municipality reserves the right to obtain such document after the closing date to verify that the signatory is in order. If no such document can be obtained within a period as specified by the Municipality, the bid will be disqualified.
- 6.4) If a bidder is a sole proprietor, no such documentation is required, provided that the document was completed and signed by the owner.

7. REGISTRATION ON THE CENTRAL SUPPLIER DATABASE (CSD)

- 7.1) It is expected of all prospective service providers who are not yet registered on the Central Supplier Database (CSD) to register without delay on the prescribed platform.

- 7.2) Prince Albert Municipality reserves the right not to award quotations to prospective suppliers who are not registered on this Database.

8. SUBMISSION OF QUOTATION

- 8.1) The quotation must be placed in a sealed envelope clearly marked with the quotation number, title as well as closing date and time and placed in the quotation box at the following location:
Prince Albert Municipal Finance Building (Thusong Centre)
Adderley Street, Prince Albert, 6930
- 8.2) Quotations can be posted to reach the quotation box of Prince Albert Municipality before the specified closing date and time. Details are as follow:
Prince Albert Municipality, Private Bag X53, Prince Albert, 6930.
- 8.3) A bid posted or couriered (at sender's risk) to the Municipality, Private Bag X53, Prince Albert, 6930, in good time so as to reach the Municipality before the above-mentioned closing date and clearly indicated "ATTENTION SUPPLY CHAIN MANAGEMENT UNIT", may be accepted on condition that it is placed in the correct Bid box before the closing time, it being understood that the Council disclaims any responsibility for seeing that such bids are in fact lodged in the bid box.
- 8.4) **Faxed, e-mailed and late quotations will not be accepted.** Quotations may be delivered by hand, by courier, or posted at the bidder's risk and must be received by the deadline specified above, irrespective of how they are sent or delivered.

9. OPENING, RECORDING AND PUBLICATION OF BIDS RECEIVED

- 9.1) Bids shall be opened in public at the Prince Albert Municipal Finance Offices immediately after the closing date and time.
- 9.2) The Municipality will record in a register (which is open to public inspection) the details of bids received by the closing date and time.
- 9.3) Any bid received after the appointed time for the closing of bids shall not be considered but shall be filed unopened with the other bids received, which bid(s) can be returned to the bidder at his request and cost.

10. CONTACT WITH MUNICIPALITY AFTER BID CLOSURE DATE

- 10.1) Bidders shall not contact the Prince Albert Municipality on any matter relating to their bid from the time of the opening of the bid to the time the contract is awarded.
- 10.2) If a bidder wishes to bring additional information to the notice of the Municipality, it should do so in writing to the Prince Albert Municipality.
- 10.3) Any attempt by the firm to influence the Prince Albert Municipality in the bid evaluation, bid comparison or contract award decisions may result in the rejection of the bid.

CHECKLIST FOR COMPLETENESS OF BIDDING DOCUMENTATION

The bidder **MUST ENSURE** that the following checklist is completed, all necessary documentation is attached to this bid and that all declarations are signed:

Mark with "X" where applicable

ITEMS TO BE CHECKED	YES / NO		
1. Completed invitation to bid (MBD 1), containing the details of the bidder	Yes		No
2. Valid and original Tax Pin Status, attached to bid document (MBD2). Bidders must indicate their pin as provided by SARS to confirm validity of their tax status.	Yes		No
3. Adhering to the price instructions (MBD 3.1)	Yes		No
4. Attached a quotation/pricing schedule on the official letterhead of the bidder's company.	Yes		No
5. Completed and signed Declaration of Interest (MBD4).	Yes		No
6. Preference points claimed and signed declarations (MBD 6.1), where applicable.	Yes		No
7. Completed and Signed Form of Offer – Purchase of Goods / Works (MBD 7.1)	Yes		No
8. Completed and Signed Form of Offer – Rendering of Services (MBD 7.2)			
9. Signed declaration of the bidder's past Supply Chain Management practices (MBD 8)	Yes		No
10. Completed and signed Certificate of Independent Bid Determination (MBD 9).	Yes		No
11. Completed and signed Certificate for Payment of Municipal Services (MBD 15).	Yes		No
12. Attached a valid B-BBEE Certificate or Sworn Affidavit, where applicable.	Yes		No
13. Attached registration at Construction Industry Development Board (CIDB), where applicable.	Yes		No
14. Attached Central Supplier Database (CSD) report.	Yes		No
15. Attached CIPC company registration documents	Yes		No
16. Attached municipal accounts of all directors of the company	Yes		No
17. Attached lease agreement of business / business municipal account in order to substantiate points for locality.	Yes		No

CERTIFICATION

I, the undersigned (full name.....), certify

that the information furnished on this checklist is true and correct.

Signed: Date:

Name: Position:

Tenderer:

MUNISIPALITEIT
VAN
PRINS ALBERT



MUNICIPALITY
OF
PRINCE ALBERT

**PART A - ADMINISTRATIVE
REQUIREMENTS IN TERMS OF THE SUPPLY
CHAIN MANAGEMENT POLICY**

PRINCE ALBERT MUNICIPALITY
MBD 1 – INVITATION TO BID
DETAILS OF TENDERER

NAME OF BIDDER:						
STREET ADDRESS:						
	City / Town				Postal Code	
POSTAL ADDRESS:						
	City / Town				Postal Code	
CONTACT PERSON						
ENTERPRISE REGISTRATION NUMBER				CIDB CRS NR (if applicable)		
TAX STATUS PIN				TELEPHONE NUMBER		
FACSIMILE NUMBER				CELLPHONE NUMBER		
EMAIL ADDRESS						

DECLARATION

I am duly authorised to represent the tenderer for the purpose of this tender and hereby tender to supply all or any of the goods and/or render all or any of the services described in the attached document to the Prince Albert Municipality on the terms and conditions stipulated in this tender document and in accordance with the specification stipulated in the tender document.

NAME (PRINT):			SIGNATURE:		
CAPACITY:			DATE:		

MBD 2 – TAX CLEARANCE REQUIREMENTS

It is a condition of tender that the taxes of the successful bidder must be in order, or that satisfactory arrangements have been made with South African Revenue Service (SARS) to meet the bidder's tax obligations, before an award may be considered.

1. The Tax Clearance Certificate/ Tax Compliance Status (TCS) Pin/ Centralised Suppliers Database (CSD) Registration Number **must be submitted together with the bid.** Failure to submit a Tax Clearance Certificate/TCS Pin/CSD registration number may result in the invalidation of the bid.

2. Tax Compliance Status (TCS) Pin as of 18 April 2016
 - 2.1) In terms of the new Tax Compliance Status System implemented by SARS on 18 April 2016, taxpayers are now able to issue the municipality with a TCS Pin which will be used to verify a bidder's tax status online via SARS E-filing.
 - 2.2) This option will be used to verify the status of the service provider (which should be active or compliant) and will determine if the offer will be further evaluated or omitted, even if the bidder only submitted a TCC as per point 1 above.
 - 2.3) Service provider's status which is found inactive or non-compliant their offers will be omitted.
 - 2.4) Bidders in possession of a valid Tax Status Pin must issue the municipality with the following:

Tax Reference Number (IT / VAT / PAYE	
Tax Compliance Status Pin	

3. In bids where Consortia / Joint Ventures / Sub-contractors are involved; each party must submit a separate Tax Compliance Status Pin or CSD Registration number.

4. Applications for the Tax Clearance Certificates may also be made via e-Filing. In order to use this provision, taxpayers will need to register with SARS as e-Filers through the website (www.sars.gov.za)

MBD 4 - DECLARATION OF INTEREST

1. No bid will be accepted from persons in the service of the state¹.
2. Any person, having a kinship with persons in the service of the state, including a blood relationship, may make an offer or offers in terms of this invitation to bid. In view of possible allegations of favouritism, should the resulting bid, or part thereof, be awarded to persons connected with or related to persons in service of the state, it is required that the bidder or their authorised representative declare their position in relation to the evaluating/adjudicating authority.
3. In order to give effect to the above, the following questionnaire must be completed and submitted with the bid.

3.1) Full Name of bidder or his/her representative:

.....

3.2) Identity Number:

3.3) Position occupied in the Company (director, trustee, shareholder²):

.....

3.4) Company Registration Number:

3.5) Tax Reference Number:

3.6) VAT Registration Number:

3.7) The names of all directors / trustees / shareholders members, their individual identity numbers and state employee numbers must be indicated in paragraph 4 below.

3.8) Are you presently in the service of the state? **YES / NO**

If yes, furnish particulars.

.....

¹MSCM Regulations: "in the service of the state" means to be –

(a) a member of –

- (i) any municipal council;
- (ii) any provincial legislature; or
- (iii) the national Assembly or the national Council of provinces;

(b) a member of the board of directors of any municipal entity;

(c) an official of any municipality or municipal entity;

(d) an employee of any national or provincial department, national or provincial public entity or constitutional institution within the meaning of the Public Finance Management Act, 1999 (Act No.1 of 1999);

(e) a member of the accounting authority of any national or provincial public entity; or

(f) an employee of Parliament or a provincial legislature.

² Shareholder" means a person who owns shares in the company and is actively involved in the management of the company or business and exercises control over the company.

3.9) Have you been in the service of the state for the past twelve months?**YES / NO**

3.9.1) If yes, furnish particulars

.....

3.10) Do you have any relationship (family, friend, other) with persons in the service of the state and who may be involved with the evaluation and or adjudication of this bid?

.....**YES / NO**

3.10.1) If yes, furnish particulars.....

.....

3.11) Are you, aware of any relationship (family, friend, other) between any other bidder and any persons in the service of the state who may be involved with the evaluation and or adjudication of this bid?.....**YES / NO**

3.11.1) If yes, furnish particulars.....

.....

3.12) Are any of the company's directors, trustees, managers, principle shareholders or stakeholders in service of the state?.....**YES / NO**

3.12.1) If yes, furnish particulars

.....

3.13) Are any spouse, child or parent of the company's directors' trustees, managers, principal shareholders or stakeholders in service of the state?.....**YES / NO**

3.13.1) If yes, furnish particulars.

.....

.....

3.14) Do you or any of the directors, trustees, managers, principal shareholders, or stakeholders of this company have any interest in any other related companies or business whether or not they are bidding for this contract?.....**YES / NO**

3.14.1) If yes, furnish particulars.....

.....

3. Full details of directors / trustees / members / shareholders.

Full Name	Identity Number	State Employee Number

.....
Signature

.....
Date

.....
Capacity

.....
Name of Bidder

MBD 6.1 - PREFERENCE POINTS CLAIM FORM IN TERMS OF THE PREFERENTIAL PROCUREMENT REGULATIONS 2022

This preference form must form part of all tenders invited. It contains general information and serves as a claim form for preference points for specific goals.

NB: BEFORE COMPLETING THIS FORM, TENDERERS MUST STUDY THE GENERAL CONDITIONS, DEFINITIONS AND DIRECTIVES APPLICABLE IN RESPECT OF THE TENDER AND PREFERENTIAL PROCUREMENT REGULATIONS, 2022

1. GENERAL CONDITIONS

1.1 The following preference point systems are applicable to invitations to tender:

- the 80/20 system for requirements with a Rand value of up to R50 000 000 (all applicable taxes included); and
- the 90/10 system for requirements with a Rand value above R50 000 000 (all applicable taxes included).

1.2 To be completed by the organ of state

(a) The **90/10 or 80/20 preference point system** will be applicable in this tender. The lowest (goods and services) / highest (sales and leases) acceptable tender will be used to determine the accurate system once tenders are received.

1.3 Points for this tender (even in the case of a tender for income-generating contracts) shall be awarded for:

- (a) Price; and
- (b) Specific Goals.

1.4 To be completed by the organ of state:

The maximum points for this tender are allocated as follows:

	POINTS	POINTS
Price	80	90
Specific goals	20	10
Total points for PRICE and SPECIFIC GOALS	100	100

1.5 Failure on the part of a tenderer to submit proof or documentation required in terms of this tender to claim points for specific goals with the tender, will be interpreted to mean that preference points for specific goals are not claimed.

1.6 The organ of state reserves the right to require of a tenderer, either before a tender is adjudicated or at any time subsequently, to substantiate any claim in regard to preferences, in any manner required by the organ of state.

2. DEFINITIONS

- a) “**tender**” means a written offer in the form determined by an organ of state in response to an invitation to provide goods or services through price quotations, competitive tendering process or any other method envisaged in legislation;
- b) “**price**” means an amount of money tendered for goods or services, and includes all applicable taxes less all unconditional discounts;
- c) “**rand value**” means the total estimated value of a contract in Rand, calculated at the time of bid invitation, and includes all applicable taxes;
- d) “**tender for income-generating contracts**” means a written offer in the form determined by an organ of state in response to an invitation for the origination of income-generating contracts through any method envisaged in legislation that will result in a legal agreement between the organ of state and a third party that produces revenue for the organ of state, and includes, but is not limited to, leasing and disposal of assets and concession contracts, excluding direct sales and disposal of assets through public auctions; and
- e) “**the Act**” means the Preferential Procurement Policy Framework Act, 2000 (Act No. 5 of 2000).

3. FORMULAE FOR PROCUREMENT OF GOODS AND SERVICES

3.1. POINTS AWARDED FOR PRICE

3.1.1 THE 80/20 OR 90/10 PREFERENCE POINT SYSTEMS

A maximum of 80 or 90 points is allocated for price on the following basis:

80/20	or	90/10
$Ps = 80 \left(1 - \frac{Pt - Pmin}{Pmin} \right)$	or	$Ps = 90 \left(1 - \frac{Pt - Pmin}{Pmin} \right)$

Where

- Ps = Points scored for price of tender under consideration
- Pt = Price of tender under consideration
- Pmin = Price of lowest acceptable tender

4. POINTS AWARDED FOR SPECIFIC GOALS

- 4.1) In terms of the Preferential Procurement Policy of Prince Albert Municipality, preference points must be awarded for specific goals stated in the tender. For the purposes of this tender the tenderer will be allocated points based on the goals stated in table 1 below as may be supported by proof/ documentation stated in the conditions of this tender:
- 4.2) In cases where organs of state intend to use Regulation 3(2) of the Regulations, which states that, if it is unclear whether the 80/20 or 90/10 preference point system applies, an organ of state must, in the tender documents, stipulate in the case of—
- (a) an invitation for tender for income-generating contracts, that either the 80/20 or 90/10 preference point system will apply and that the highest acceptable tender will be used to determine the applicable preference point system; or
 - (b) any other invitation for tender, that either the 80/20 or 90/10 preference point system will apply and that the lowest acceptable tender will be used to determine the applicable preference point system,
- then the organ of state must indicate the points allocated for specific goals for both the 90/10 and 80/20 preference point system.

SPECIFIC GOALS

SPECIFIC GOALS FOR THE TENDER AND POINTS CLAIMED ARE INDICATED PER THE TABLE BELOW.

- Note to **organs of state**: Where either the 90/10 or 80/20 preference point system is applicable, corresponding points must also be indicated as such.
- Note to **tenderers**: The tenderer must indicate how they claim points for each preference point system.)

The specific goals allocated points in terms of this tender	Number of points allocated i.t.o. (80/20 system) (To be completed by the organ of state)
B-BBEE preference points	10 points
Locality	10 points

- 4.3) A maximum of 20 points (80/20 preference points system) or 10 (90/10) preference points system), will be allocated for specific goals. These goals are:
- a) contracting with persons, or categories of persons, historically disadvantaged by unfair discrimination on the basis of race, gender or disability (BBBEE);
 - b) Promotion of enterprises located in the municipal area

4.4) Regarding par 4.3 (a) 50% of the 20/10 points will be allocated to promote this goal and points will be allocated in terms of the BBBEE scorecard as follows:

B-BBEE Status Level of Contributor	Number of Points for Preference (80/20)	50% of Points for Preference
1	20	10
2	18	9
3	16	8
4	12	6
5	8	4
6	6	3
7	4	2
8	2	1
Non-compliant contributor	0	0

- (a) tenderer must submit proof of its B-BBEE status level contributor [scorecard].
- (b) A tenderer failing to submit proof of B-BBEE status level of contributor may only score in terms of the 80-point formula for price; and scores 0 points for B-BBEE status level of contributor.

4.4.1) B-BBEE STATUS LEVEL OF CONTRIBUTOR CLAIMED IN TERMS OF PARAGRAPH 4.1

B-BBEE Status Level of Contributor:

Only indicate your B-BBEE Status Level of Contributor – the points will be calculated by the Municipality)

4.4.2) LOCALITY

Points for specific goals to promote suppliers or service providers located in a province, district or municipal area / (hereafter referred to as locality)

- (a) Each tender must specify in the invitation to tender that a maximum of 50% of the 20 points will be allocated to promote the specific goal of locality.
- (b) Only one of the points as set out below that best describes the enterprise's locality may be awarded if applicable.

LOCALITY OF SUPPLIER/ LOCAL LABOUR	POINTS
Within the boundaries of the municipality	10
Outside municipal boundaries, but within boundaries of district (Central Karoo)	8
Outside boundaries of municipality and district, but within Western Cape Province	5
Outside of the Western Cape Province	0

(a) Bidders must submit one of the following in order to receive points for the abovementioned criterion.

- (i) Municipal Account of address as indicated in bid document;
- (ii) If the address as indicated in bid document is not in the name of the bidder, the latest lease agreement for this address or sworn affidavit of the owner stating occupancy.
- (iii) The premises of the bidder as indicated in the MBD6.1 of the bid document as the business address should be established prior to the advertisement date.

LOCALITY CLAIMED IN TERMS OF PARAGRAPHS 4.4

Locality (indicate as per table above) :
(The address provided in 4.5 below, will be used to determine the locality as per 4.4.1 above).

4.5) MUNICIPAL INFORMATION

Municipality where business is situated:
Registered Account Number:
Stand Number:

4.6) NAME OF

COMPANY/FIRM:.....

4.7) COMPANY REGISTRATION NUMBER

.....

4.8) TYPE OF COMPANY/ FIRM

- Partnership/Joint Venture / Consortium
- One-person business/sole propriety
- Close corporation
- Public Company
- Personal Liability Company
- (Pty) Limited
- Non-Profit Company
- State Owned Company

[TICK APPLICABLE BOX]

4.9) I, the undersigned, who is duly authorised to do so on behalf of the company/firm, certify that the points claimed, based on the specific goals as advised in the tender, qualifies the company/ firm for the preference(s) shown and I acknowledge that:

- i) The information furnished is true and correct;
- ii) The preference points claimed are in accordance with the General Conditions as indicated in paragraph 1 of this form;
- iii) In the event of a contract being awarded as a result of points claimed as shown in paragraphs 1.4 and 4.2, the contractor may be required to furnish documentary proof to the satisfaction of the organ of state that the claims are correct;
- iv) If the specific goals have been claimed or obtained on a fraudulent basis or any of the conditions of contract have not been fulfilled, the organ of state may, in addition to any other remedy it may have –

- (a) disqualify the person from the tendering process;
- (b) recover costs, losses or damages it has incurred or suffered as a result of that person's conduct;
- (c) cancel the contract and claim any damages which it has suffered as a result of having to make less favourable arrangements due to such cancellation;
- (d) recommend that the tenderer or contractor, its shareholders and directors, or only the shareholders and directors who acted on a fraudulent basis, be restricted from obtaining business from any organ of state for a period not exceeding 10 years, after the *audi alteram partem* (hear the other side) rule has been applied; and
- (e) forward the matter for criminal prosecution, if deemed necessary

.....
SIGNATURE(S) OF BIDDER(S)

DATE:

ADDRESS:
.....
.....

WITNESSES:

1.

2.

MBD 8 - DECLARATION OF BIDDER'S PAST SUPPLY CHAIN MANAGEMENT PRACTICES

This Municipal Bidding Document must form part of all bids invited.

- 1 It serves as a declaration to be used by municipalities and municipal entities in ensuring that when goods and services are being procured, all reasonable steps are taken to combat the abuse of the supply chain management system.

- 2 The bid of any bidder may be rejected if that bidder, or any of its directors have:
 - a. abused the municipality's / municipal entity's supply chain management system or committed any improper conduct in relation to such system;
 - b. been convicted for fraud or corruption during the past five years;
 - c. willfully neglected, reneged on or failed to comply with any government, municipal or other public sector contract during the past five years; or
 - d. been listed in the Register for Tender Defaulters in terms of section 29 of the Prevention and Combating of Corrupt Activities Act (No 12 of 2004).

- 3 **In order to give effect to the above, the following questionnaire must be completed and submitted with the bid.**

Item	Question	Yes	No
4.1	<p>Is the bidder or any of its directors listed on the National Treasury's database as a company or person prohibited from doing business with the public sector?</p> <p>(Companies or persons who are listed on this database were informed in writing of this restriction by the National Treasury after the <i>audi alteram partem</i> rule was applied).</p>	Yes <input type="checkbox"/>	No <input type="checkbox"/>
4.1.1	If so, furnish particulars:		
4.2	<p>Is the bidder or any of its directors listed on the Register for Tender Defaulters in terms of section 29 of the Prevention and Combating of Corrupt Activities Act (No 12 of 2004)?</p> <p>(To access this Register enter the National Treasury's website, www.treasury.gov.za, click on the icon "Register for Tender Defaulters" or submit your written request for a hard copy of the Register to facsimile number (012) 3265445).</p>	Yes <input type="checkbox"/>	No <input type="checkbox"/>

4.2.1	If so, furnish particulars:		
4.3	Was the bidder or any of its directors convicted by a court of law (including a court of law outside the Republic of South Africa) for fraud or corruption during the past five years?	Yes <input type="checkbox"/>	No <input type="checkbox"/>
4.3.1	If so, furnish particulars:		
Item	Question	Yes	No
4.4	Does the bidder or any of its directors owe any municipal rates and taxes or municipal charges to the municipality / municipal entity, or to any other municipality / municipal entity, that is in arrears for more than three months?	Yes <input type="checkbox"/>	No <input type="checkbox"/>
4.4.1	If so, furnish particulars:		
4.5	Was any contract between the bidder and the municipality / municipal entity or any other organ of state terminated during the past five years on account of failure to perform on or comply with the contract?	Yes <input type="checkbox"/>	No <input type="checkbox"/>
4.7.1	If so, furnish particulars:		

CERTIFICATION

I, THE UNDERSIGNED (FULL NAME)
CERTIFY THAT THE INFORMATION FURNISHED ON THIS
DECLARATION FORM TRUE AND CORRECT.

I ACCEPT THAT, IN ADDITION TO CANCELLATION OF A CONTRACT,
ACTION MAY BE TAKEN AGAINST ME SHOULD THIS DECLARATION
PROVE TO BE FALSE.

.....
Signature

.....
Date

.....
Position

.....
Name of Bidder

MBD 9 - CERTIFICATE OF INDEPENDENT BID DETERMINATION

- 1 This Municipal Bidding Document (MBD) must form part of all bids¹ invited.

- 2 Section 4 (1) (b) (iii) of the Competition Act No. 89 of 1998, as amended, prohibits an agreement between, or concerted practice by, firms, or a decision by an association of firms, if it is between parties in a horizontal relationship and if it involves collusive bidding (or bid rigging).² Collusive bidding is a *pe se* prohibition meaning that it cannot be justified under any grounds.

- 3 Municipal Supply Regulation 38 (1) prescribes that a supply chain management policy must provide measures for the combating of abuse of the supply chain management system, and must enable the accounting officer, among others, to:
 - a. take all reasonable steps to prevent such abuse;
 - b. reject the bid of any bidder if that bidder or any of its directors has abused the supply chain management system of the municipality or municipal entity or has committed any improper conduct in relation to such system; and
 - c. cancel a contract awarded to a person if the person committed any corrupt or fraudulent act during the bidding process or the execution of the contract.

- 4 This MBD serves as a certificate of declaration that would be used by institutions to ensure that, when bids are considered, reasonable steps are taken to prevent any form of bid-rigging.

- 5 In order to give effect to the above, the attached Certificate of Bid Determination (MBD 9) must be completed and submitted with the bid:

¹ Includes price quotations, advertised competitive bids, limited bids and proposals.

² Bid rigging (or collusive bidding) occurs when businesses, that would otherwise be expected to compete, secretly conspire to raise prices or lower the quality of goods and / or services for purchasers who wish to acquire goods and / or services through a bidding process. Bid rigging is, therefore, an agreement between competitors not to compete

CERTIFICATE OF INDEPENDENT BID DETERMINATION

I, the undersigned, in submitting the accompanying bid:

RFQ 181 / 2025 - APPOINTMENT OF A SPECIALISED SERVICE PROVIDER FOR THE ASSESSMENT , AND REPLACEMENT AND MAINTENANCE OF PUMPS AND MOTORS AT PRINCE ALBERT MUNICIPALITY’S WATER AND TREATMENT PLANTS AND PUMP STATIONS ENDING 30 JUNE 2026

in response to the invitation for the bid made by:

PRINCE ALBERT MUNICIPALITY

(Name of Municipality / Municipal Entity)

do hereby make the following statements that I certify to be true and complete in every respect:

I certify, on behalf of:

_____ that:

(Name of Bidder)

1. I have read and I understand the contents of this Certificate;
2. I understand that the accompanying bid will be disqualified if this Certificate is found not to be true and complete in every respect;
3. I am authorized by the bidder to sign this Certificate, and to submit the accompanying bid, on behalf of the bidder;
4. Each person whose signature appears on the accompanying bid has been authorized by the bidder to determine the terms of, and to sign, the bid, on behalf of the bidder;
5. For the purposes of this Certificate and the accompanying bid, I understand that the word “competitor” shall include any individual or organization, other than the bidder, whether or not affiliated with the bidder, who:
 - a) has been requested to submit a bid in response to this bid invitation;
 - b) could potentially submit a bid in response to this bid invitation, based on their qualifications, abilities or experience; and
 - c) provides the same goods and services as the bidder and/or is in the same line of business as the bidder

- d) The bidder has arrived at the accompanying bid independently from, and without consultation, communication, agreement or arrangement with any competitor. However, communication between partners in a joint venture or consortium³ will not be construed as collusive bidding.
- e) In particular, without limiting the generality of paragraphs 6 above, there has been no consultation, communication, agreement or arrangement with any competitor regarding:
 - (a) prices;
 - (b) geographical area where product or service will be rendered (market allocation)
 - (c) methods, factors or formulas used to calculate prices;
 - (d) the intention or decision to submit or not to submit, a bid;
 - (e) the submission of a bid which does not meet the specifications and conditions of the bid; or
 - (f) bidding with the intention not to win the bid.
- f) In addition, there have been no consultations, communications, agreements or arrangements with any competitor regarding the quality, quantity, specifications and conditions or delivery particulars of the products or services to which this bid invitation relates.
- g) The terms of the accompanying bid have not been, and will not be, disclosed by the bidder, directly or indirectly, to any competitor, prior to the date and time of the official bid opening or of the awarding of the contract.

³ Joint venture or Consortium means an association of persons for the purpose of combining their expertise, property, capital, efforts, skill and knowledge in an activity for the execution of a contract.

10. I am aware that, in addition and without prejudice to any other remedy provided to combat any restrictive practices related to bids and contracts, bids that are suspicious will be reported to the Competition Commission for investigation and possible imposition of administrative penalties in terms of section 59 of the Competition Act No 89 of 1998 and or may be reported to the National Prosecuting Authority (NPA) for criminal investigation and or may be restricted from conducting business with the public sector for a period not exceeding ten (10) years in terms of the Prevention and Combating of Corrupt Activities Act No 12 of 2004 or any other applicable legislation.

.....
Signature

.....
Date

.....
Position

.....
Name of Bidder

PRINCE ALBERT MUNICIPALITY

MBD 15 – CERTIFICATE FOR PAYMENT OF MUNICIPAL SERVICES

(To be signed in the presence of a Commissioner of Oaths)

I, the undersigned, in submitting the accompanying bid, declare that I am duly authorised to act on behalf on:	<i>(Name of Enterprise)</i>
--	-----------------------------

I hereby acknowledge that according to SCM Regulation 38(1)(d)(i), the Municipality may reject the tender of the tenderer if any municipal rates and taxes or municipal service charges owed by the Tenderer or any of its directors/members/partners to the Prince Albert Municipality, or to any other municipality or municipal entity, are in arrears for more than 3 (three) months.

To the best of my personal knowledge, neither the firm nor any director/member/partner of said firm is in arrears on any of its municipal accounts with any municipality in the Republic of South Africa, for a period longer than 3 (three) months.

If the value of the transaction is expected to exceed R10 million (VAT included) I certify that the bidder has no undisputed commitments for municipal services towards any Municipality in respect of which payment is overdue for more than 30 days;

PHYSICAL BUSINESS ADDRESS(ES) OF THE TENDERER	MUNICIPAL ACCOUNT NUMBER

FURTHER DETAILS OF THE BIDDER’S (Directors / Shareholders / Partners, etc.):

Director / Shareholder / Partner	Physical address of the Business	Municipal Account Number (s)	Physical / Residential address of the Director / Shareholder / Partner	Municipal Account Number (s)

NB: PLEASE ATTACH CERTIFIED COPY(IES) OF IDENTITY DOCUMENT(S) OF ALL DIRECTORS. Failure to comply will result in your bid being marked as non-responsive.

NB: PLEASE ATTACH COPY(IES) OF MUNICIPAL ACCOUNTS.

NUMBER OF SHEETS APPENDED BY THE TENDERER TO THIS SCHEDULE (IF NUL, ENTER NIL).	
---	--

Therefore, hereby agrees and authorises the Prince Albert Municipality to deduct the full amount outstanding by the Tenderer or any of its directors / members / partners from any payment due to the tenderer; and

I further hereby certify that the information set out in this schedule and/or attachment(s) hereto is true and correct. The Tenderer acknowledges that failure to properly and truthfully complete this schedule may result in the tender being disqualified, and/or in the event that the tenderer is successful, the cancellation of the contract.

NAME OF ENTERPRISE:			
NAME (PRINT):			
CAPACITY:			
SIGNATURE:		DATE:	

<p style="text-align: center;">COMMISSIONER OF OATHS</p> <p>Signed and sworn to before me at _____, on this _____ day of _____ 20__</p> <p>by the Deponent, who has acknowledged that he/she knows and understands the contents of this Affidavit, it is true and correct to the best of his/her knowledge and that he/she has no objection to taking the prescribed oath, and that the prescribed oath will be binding on his/her conscience.</p> <p>COMMISSIONER OF OATHS:</p> <p>Position: _____</p> <p>Address: _____</p> <p>Tel: _____</p>	<p>Apply official stamp of authority on this</p> <p>page:</p>
--	---

GENERAL CONDITIONS OF CONTRACT

1. DEFINITIONS

The following terms shall be interpreted as indicated:

“Closing time”	means the date and hour specified in the bidding documents for the receipt of bids.
“Contract”	means the written agreement entered into between the purchaser and the supplier, as recorded in the contract form signed by the parties, including all attachments and appendices thereto and all documents incorporated by reference therein
“Contract price”	means the price payable to the supplier under the contract for the full and proper performance of his contractual obligations.
“Corrupt practice”	means the offering, giving, receiving, or soliciting of any thing of value to influence the action of a public official in the procurement process or in contract execution.
“Countervailing duties”	are imposed in cases where an enterprise abroad is subsidized by its government and encouraged to market its products internationally
“Country of origin”	means the place where the goods were mined, grown or produced or from which the services are supplied. Goods are produced when, through manufacturing, processing or substantial and major assembly of components, a commercially recognized new product results that is substantially different in basic characteristics or in purpose or utility from its components.
“Day”	means calendar day.
“Delivery”	means delivery in compliance of the conditions of the contract or order.
“Delivery ex stock”	means immediate delivery directly from stock actually on hand
“Delivery into consignees store or to his site”	means delivered and unloaded in the specified store or depot or on the specified site in compliance with the conditions of the contract or order, the supplier bearing all risks and charges involved until the supplies are so delivered and a valid receipt is obtained.
“Dumping”	occurs when a private enterprise abroad market its goods on own initiative in the RSA at lower prices than that of the country of origin and which have the potential to harm the local industries in the RSA.
”Force majeure”	means an event beyond the control of the supplier and not involving the supplier’s fault or negligence and not foreseeable. Such events may include, but is not restricted to, acts of the purchaser in its sovereign capacity, wars or revolutions, fires, floods, epidemics, quarantine restrictions and freight embargoes.

“Fraudulent practice”	means a misrepresentation of facts in order to influence a procurement process or the execution of a contract to the detriment of any bidder, and includes collusive practice among bidders (prior to or after bid submission) designed to establish bid prices at artificial non-competitive levels and to deprive the bidder of the benefits of free and open competition.
“GCC”	means the General Conditions of Contract.
“Goods”	means all of the equipment, machinery, and/or other materials that the supplier is required to supply to the purchaser under the contract
“Imported content”	means that portion of the bidding price represented by the cost of components, parts or direct importation costs such as landing costs, dock dues, import duty, sales duty or other similar tax or duty at the South African place of entry as well as transportation and handling charges to the factory in the Republic where the supplies covered by the bid will be charges to the factory in the Republic where the supplies covered by the bid will be manufactured.
“Local content”	means that portion of the bidding price which is not included in the imported content provided that local manufacture does take place.
“Manufacture”	means the production of products in a factory using labour, materials, components and machinery and includes other related value-adding activities.
“Order”	means an official written order issued for the supply of goods or works or the rendering of a service.
“Project site”	where applicable, means the place indicated in bidding documents.
“Purchaser”	means the organization purchasing the goods.
“Republic”	means the Republic of South Africa.
“SCC”	means the Special Conditions of Contract.
“Services”	means that functional services ancillary to the supply of the goods, such as transportation and any other incidental services, such as installation, commissioning, provision of technical assistance, training, catering, gardening, security, maintenance and other such obligations of the supplier covered under the contract.
“Supplier”	means the successful bidder who is awarded the contract to maintain and administer the required and specified service(s) to the State.
“Tort”	means in breach of contract.
“Turnkey”	means a procurement process where one service provider assumes total responsibility for all aspects of the project and delivers the full end product / service required by the contract
“Written” or “in writing”	means handwritten in ink or any form of electronic or mechanical writing.

2. APPLICATION

- 2.1) These general conditions are applicable to all bids, contracts and orders including bids for functional and professional services, sales, hiring, letting and the granting or acquiring of rights, but excluding immovable property, unless otherwise indicated in the bidding documents.
- 2.2) Where applicable, special conditions of contract are also laid down to cover specific supplies, services or works.
- 2.3) Where such special conditions of contract are in conflict with these general conditions, the special conditions shall apply.

3. GENERAL

- 3.1) Unless otherwise indicated in the bidding documents, the purchaser shall not be liable for any expense incurred in the preparation and submission of a bid. Where applicable a non-refundable fee for documents may be charged.
- 3.2) Invitations to bid are usually published in locally distributed news media and on the municipality / municipal entity website.

4. STANDARDS

- 4.1) The goods supplied shall conform to the standards mentioned in the bidding documents and specifications.

5. USE OF CONTRACT DOCUMENTS AND INFORMATION; INSPECTION

- 5.1) The supplier shall not, without the purchaser's prior written consent, disclose the contract, or any provision thereof, or any specification, plan, drawing, pattern, sample, or information furnished by or on behalf of the purchaser in connection therewith, to any person other than a person employed by the supplier in the performance of the contract. Disclosure to any such employed person shall be made in confidence and shall extend only as far as may be necessary for purposes of such performance.
- 5.2) The supplier shall not, without the purchaser's prior written consent, make use of any document or information mentioned in GCC clause 5.1 except for purposes of performing the contract.
- 5.3) Any document, other than the contract itself mentioned in GCC clause 5.1 shall remain the property of the purchaser and shall be returned (all copies) to the purchaser on completion of the supplier's performance under the contract if so required by the purchaser.
- 5.4) The supplier shall permit the purchaser to inspect the supplier's records relating to the performance of the supplier and to have them audited by auditors appointed by the purchaser, if so required by the purchaser.

6. PATENT RIGHTS

- 6.1) The supplier shall indemnify the purchaser against all third-party claims of infringement of patent, trademark, or industrial design rights arising from use of the goods or any part thereof by the purchaser.

- 6.2) When a supplier developed documentation / projects for the municipality / municipal entity, the intellectual, copy and patent rights or ownership of such documents or projects will vest in the municipality / municipal entity.

7. PERFORMANCE SECURITY

- 7.1) Within thirty (30) days of receipt of the notification of contract award, the successful bidder shall furnish to the purchaser the performance security of the amount specified in SCC.
- 7.2) The proceeds of the performance security shall be payable to the purchaser as compensation for any loss resulting from the supplier's failure to complete his obligations under the contract.
- 7.3) The performance security shall be denominated in the currency of the contract or in a freely convertible currency acceptable to the purchaser and shall be in one of the following forms:
- 7.3.1) bank guarantee or an irrevocable letter of credit issued by a reputable bank located in the purchaser's country or abroad, acceptable to the purchaser, in the form provided in the bidding documents or another form acceptable to the purchaser; or
- 7.3.2) a cashier's or certified cheque
- 7.4) The performance security will be discharged by the purchaser and returned to the supplier not later than thirty (30) days following the date of completion of the supplier's performance obligations under the contract, including any warranty obligations, unless otherwise specified.

8. INSPECTIONS, TESTS AND ANALYSES

- 8.1) All pre-bidding testing will be for the account of the bidder.
- 8.2) If it is a bid condition that supplies to be produced or services to be rendered should at any stage during production or execution or on completion be subject to inspections tests and analysis, the bidder or contractor's premises shall be open, at all reasonable hours, for inspection by a representative of the purchaser or an organization acting on behalf of the purchaser.
- 8.3) If there are no inspection requirements indicated in the bidding documents and no mention is made in the contract, but during the contract period it is decided that inspections shall be carried out, the purchaser shall itself make the necessary arrangements, including payment arrangements with the testing authority concerned.
- 8.4) If the inspections, tests and analyses referred to in clauses 8.2 and 8.3 show the goods to be in accordance with the contract requirements, the cost of the inspections, tests and analyses shall be defrayed by the purchaser.
- 8.5) Where the goods or services referred to in clauses 8.2 and 8.3 do not comply with the contract requirements, irrespective of whether such goods or services are accepted or not, the cost in connection with these inspections, tests or analyses shall be defrayed by the supplier.
- 8.6) Supplies and services which are referred to in clauses 8.2 and 8.3 and which do not comply with the contract requirements may be rejected.
- 8.7) Any contract goods may on or after delivery be inspected, tested or analysed and may be rejected if found not to comply with the requirements of the contract. Such rejected goods shall

be held at the cost and risk of the supplier who shall, when called upon, remove them immediately at his own cost and forthwith substitute them with goods which do comply with the requirements of the contract. Failing such removal, the rejected goods shall be returned at the suppliers cost and risk. Should the supplier fail to provide the substitute goods forthwith, the purchaser may, without giving the supplier further opportunity to substitute the rejected goods, purchase such goods as may be necessary at the expense of the supplier.

- 8.8) The provisions of clauses 8.4 to 8.7 shall not prejudice the right of the purchaser to cancel the contract on account of a breach of the conditions thereof, or to act in terms of Clause 22 of GCC.

9. PACKING

- 9.1) The supplier shall provide such packing of the goods as is required to prevent their damage or deterioration during transit to their final destination, as indicated in the contract. The packing shall be sufficient to withstand, without limitation, rough handling during transit and exposure to extreme temperatures, salt and precipitation during transit, and open storage. Packing, case size and weights shall take into consideration, where appropriate, the remoteness of the goods' final destination and the absence of heavy handling facilities at all points in transit.
- 9.2) The packing, marking, and documentation within and outside the packages shall comply strictly with such special requirements as shall be expressly provided for in the contract, including additional requirements, and in any subsequent instructions ordered by the purchaser.

10. DELIVERY

- 10.1) Delivery of the goods shall be made by the supplier in accordance with the documents and terms specified in the contract. The details of shipping and/or other documents to be furnished by the supplier are specified.

11. INSURANCE

- 11.1) The goods supplied under the contract shall be fully insured in a freely convertible currency against loss or damage incidental to manufacture or acquisition, transportation, storage and delivery in the manner specified.

12. TRANSPORTATION

- 12.1) Should a price other than an all-inclusive delivered price be required, this shall be specified.

13. INCIDENTAL

- 13.1) The supplier may be required to provide any or all of the following services, including additional services, if any:
- 13.1.1) performance or supervision of on-site assembly and/or commissioning of the supplied goods;

- 13.1.2) furnishing of tools required for assembly and/or maintenance of the supplied goods;
 - 13.1.3) furnishing of a detailed operations and maintenance manual for each appropriate unit of the supplied goods;
 - 13.1.4) performance or supervision or maintenance and/or repair of the supplied goods, for a period of time agreed by the parties, provided that this service shall not relieve the supplier of any warranty obligations under this contract; and
 - 13.1.5) training of the purchaser's personnel, at the supplier's plant and/or on-site, in assembly, start-up, operation, maintenance, and/or repair of the supplied goods.
- 13.2) Prices charged by the supplier for incidental services, if not included in the contract price for the goods, shall be agreed upon in advance by the parties and shall not exceed the prevailing rates charged to other parties by the supplier for similar services.

14. SPARE PARTS

- 14.1)** As specified, the supplier may be required to provide any or all of the following materials, notifications, and information pertaining to spare parts manufactured or distributed by the supplier:
- 14.1.1) such spare parts as the purchaser may elect to purchase from the supplier, provided that this election shall not relieve the supplier of any warranty obligations under the contract; and;
 - 14.1.2) in the event of termination of production of the spare parts:
 - 14.1.2.1) advance notification to the purchaser of the pending termination, in sufficient time to permit the purchaser to procure needed requirements; and
 - 14.1.2.2) following such termination, furnishing at no cost to the purchaser, the blueprints, drawings, and specifications of the spare parts, if requested.

15. WARRANTY

- 15.1) The supplier warrants that the goods supplied under the contract are new, unused, of the most recent or current models, and that they incorporate all recent improvements in design and materials unless provided otherwise in the contract. The supplier further warrants that all goods supplied under this contract shall have no defect, arising from design, materials, or workmanship (except when the design and/or material is required by the purchaser's specifications) or from any act or omission of the supplier, that may develop under normal use of the supplied goods in the conditions prevailing in the country of final destination.
- 15.2) This warranty shall remain valid for twelve (12) months after the goods, or any portion thereof as the case may be, have been delivered to and accepted at the final destination indicated in the contract, or for eighteen (18) months after the date of shipment from the port or place of loading in the source country, whichever period concludes earlier, unless specified otherwise in SCC.
- 15.3) The purchaser shall promptly notify the supplier in writing of any claims arising under this warranty.

- 15.4) Upon receipt of such notice, the supplier shall, within the period specified in SCC and with all reasonable speed, repair or replace the defective goods or parts thereof, without costs to the purchaser.
- 15.5) If the supplier, having been notified, fails to remedy the defect(s) within the period specified, the purchaser may proceed to take such remedial action as may be necessary, at the supplier's risk and expense and without prejudice to any other rights which the purchaser may have against the supplier under the contract.

16. PAYMENT

- 16.1) The method and conditions of payment to be made to the supplier under this contract shall be specified.
- 16.2) The supplier shall furnish the purchaser with an invoice accompanied by a copy of the delivery note and upon fulfilment of other obligations stipulated in the contract.
- 16.3) Payments shall be made by the purchaser no later than thirty (30) days after submission of an invoice, statement or claim by the supplier.
- 16.4) Payment will be made in Rand unless otherwise stipulated.

17. PRICES

- 17.1) Prices charged by the supplier for goods delivered and services performed under the contract shall not vary from the prices quoted by the supplier in his bid, with the exception of any price adjustments authorized or in the purchaser's request for bid validity extension, as the case may be.

18. VARIATION ORDERS

- 18.1) In cases where the estimated value of the envisaged changes in purchase does not vary more than 15% of the total value of the original contract, the contractor may be instructed to deliver the goods or render the services as such. In cases of measurable quantities, the contractor may be approached to reduce the unit price and such offers, may be accepted provided that there is no escalation in price.

19. ASSIGNMENT

- 19.1) The supplier shall not assign, in whole or in part, its obligations to perform under the contract, except with the purchaser's prior written consent.

20. SUBCONTRACTS

- 20.1) The supplier shall notify the purchaser in writing of all subcontracts awarded under this contract, if not already specified in the bid. Such notification, in the original bid or later, shall not relieve the supplier from any liability or obligation under the contract.

21. DELAYS IN THE SUPPLIER'S PERFORMANCE

- 21.1) Delivery of the goods and performance of services shall be made by the supplier in accordance with the time schedule prescribed by the purchaser in the contract.
- 21.2) If at any time during performance of the contract, the supplier or its subcontractor(s) should encounter conditions impeding timely delivery of the goods and performance of services, the supplier shall promptly notify the purchaser in writing of the fact of the delay, its likely duration and its cause(s). As soon as practicable after receipt of the supplier's notice, the purchaser shall evaluate the situation and may at his discretion extend the supplier's time for performance, with or without the imposition of penalties, in which case the extension shall be ratified by the parties by amendment of contract.
- 21.3) The right is reserved to procure outside of the contract small quantities or to have minor essential services executed if an emergency arises, the supplier's point of supply is not situated at or near the place where the supplies are required, or the supplier's services are not readily available.
- 21.4) Except as provided under GCC Clause 25, a delay by the supplier in the performance of its delivery obligations shall render the supplier liable to the imposition of penalties, pursuant to GCC Clause 22, unless an extension of time is agreed upon pursuant to GCC Clause 22 without the application of penalties.
- 21.5) Upon any delay beyond the delivery period in the case of a supplies contract, the purchaser shall, without cancelling the contract, be entitled to purchase supplies of a similar quality and up to the same quantity in substitution of the goods not supplied in conformity with the contract and to return any goods delivered later at the supplier's expense and risk, or to cancel the contract and buy such goods as may be required to complete the contract and without prejudice to his other rights, be entitled to claim damages from the supplier.

22. PENALTIES

- 22.1) Subject to GCC Clause 25, if the supplier fails to deliver any or all of the goods or to perform the services within the period(s) specified in the contract, the purchaser shall, without prejudice to its other remedies under the contract, deduct from the contract price, as a penalty, a sum calculated on the delivered price of the delayed goods or unperformed services using the current prime interest rate calculated for each day of the delay until actual delivery or performance. The purchaser may also consider termination of the contract pursuant to GCC Clause 23.

23. TERMINATION FOR DEFAULT

- 23.1) The purchaser, without prejudice to any other remedy for breach of contract, by written notice of default sent to the supplier, may terminate this contract in whole or in part:

- 23.1.1) if the supplier fails to deliver any or all of the goods within the period(s) specified in the contract, or within any extension thereof granted by the purchaser pursuant to GCC Clause 21.2;
 - 23.1.2) if the Supplier fails to perform any other obligation(s) under the contract; or
 - 23.1.3) if the supplier, in the judgment of the purchaser, has engaged in corrupt or fraudulent practices in competing for or in executing the contract.
- 23.2) In the event the purchaser terminates the contract in whole or in part, the purchaser may procure, upon such terms and in such manner as it deems appropriate, goods, works or services similar to those undelivered, and the supplier shall be liable to the purchaser for any excess costs for such similar goods, works or services. However, the supplier shall continue performance of the contract to the extent not terminated.
- 23.3) Where the purchaser terminates the contract in whole or in part, the purchaser may decide to impose a restriction penalty on the supplier by prohibiting such supplier from doing business with the public sector for a period not exceeding 10 years.
- 23.4) If a purchaser intends imposing a restriction on a supplier or any person associated with the supplier, the supplier will be allowed a time period of not more than fourteen (14) days to provide reasons why the envisaged restriction should not be imposed. Should the supplier fail to respond within the stipulated fourteen (14) days the purchaser may regard the supplier as having no objection and proceed with the restriction.
- 23.5) Any restriction imposed on any person by the purchaser will, at the discretion of the purchaser, also be applicable to any other enterprise or any partner, manager, director or other person who wholly or partly exercises or exercised or may exercise control over the enterprise of the first-mentioned person, and with which enterprise or person the first-mentioned person, is or was in the opinion of the purchase actively associated.
- 23.6) If a restriction is imposed, the purchaser must, within five (5) working days of such imposition, furnish the National Treasury, with the following information:
- 23.6.1) the name and address of the supplier and / or person restricted by the purchaser;
 - 23.6.2) the date of commencement of the restriction
 - 23.6.3) the period of restriction; and
 - 23.6.4) the reasons for the restriction.

These details will be loaded in the National Treasury's central database of suppliers or persons prohibited from doing business with the public sector.

- 23.7) If a court of law convicts a person of an offence as contemplated in sections 12 or 13 of the Prevention and Combating of Corrupt Activities Act, No. 12 of 2004, the court may also rule that such person's name be endorsed on the Register for Tender Defaulters. When a person's name has been endorsed on the Register, the person will be prohibited from doing business with the public sector for a period not less than five years and not more than 10 years. The National Treasury is empowered to determine the period of restriction and each case will be

dealt with on its own merits. According to section 32 of the Act the Register must be open to the public. The Register can be perused on the National Treasury website.

24. ANTI-DUMPING AND COUNTERVAILING DUTIES AND RIGHTS

- 24.1) When, after the date of bid, provisional payments are required, or antidumping or countervailing duties are imposed, or the amount of a provisional payment or anti-dumping or countervailing right is increased in respect of any dumped or subsidized import, the State is not liable for any amount so required or imposed, or for the amount of any such increase. When, after the said date, such a provisional payment is no longer required or any such anti-dumping or countervailing right is abolished, or where the amount of such provisional payment or any such right is reduced, any such favourable difference shall on demand be paid forthwith by the contractor to the State or the State may deduct such amounts from moneys (if any) which may otherwise be due to the contractor in regard to supplies or services which he delivered or rendered, or is to deliver or render in terms of the contract or any other contract or any other amount which may be due to him.

25. FORCE MAJEURE

- 25.1) Notwithstanding the provisions of GCC Clauses 22 and 23, the supplier shall not be liable for forfeiture of its performance security, damages, or termination for default if and to the extent that his delay in performance or other failure to perform his obligations under the contract is the result of an event of force majeure.
- 25.2) If a force majeure situation arises, the supplier shall promptly notify the purchaser in writing of such condition and the cause thereof. Unless otherwise directed by the purchaser in writing, the supplier shall continue to perform its obligations under the contract as far as is reasonably practical, and shall seek all reasonable alternative means for performance not prevented by the force majeure event.

26. TERMINATION FOR INSOLVENCY

- 26.1) The purchaser may at any time terminate the contract by giving written notice to the supplier if the supplier becomes bankrupt or otherwise insolvent. In this event, termination will be without compensation to the supplier, provided that such termination will not prejudice or affect any right of action or remedy which has accrued or will accrue thereafter to the purchaser.

27. SETTLEMENT OF DISPUTES

- 27.1) If any dispute or difference of any kind whatsoever arises between the purchaser and the supplier in connection with or arising out of the contract, the parties shall make every effort to resolve amicably such dispute or difference by mutual consultation.
- 27.2) If, after thirty (30) days, the parties have failed to resolve their dispute or difference by such mutual consultation, then either the purchaser or the supplier may give notice to the other party

of his intention to commence with mediation. No mediation in respect of this matter may be commenced unless such notice is given to the other party.

27.3) Should it not be possible to settle a dispute by means of mediation, it may be settled in a South African court of law.

27.4) Notwithstanding any reference to mediation and/or court proceedings herein,

27.4.1) the parties shall continue to perform their respective obligations under the contract unless they otherwise agree; and

27.4.2) the purchaser shall pay the supplier any monies due for goods delivered and / or services rendered according to the prescripts of the contract.

28. LIMITATION OF LIABILITY

28.1) Except in cases of criminal negligence or wilful misconduct, and in the case of infringement pursuant to Clause 6;

28.1.1) the supplier shall not be liable to the purchaser, whether in contract, tort, or otherwise, for any indirect or consequential loss or damage, loss of use, loss of production, or loss of profits or interest costs, provided that this exclusion shall not apply to any obligation of the supplier to pay penalties and/or damages to the purchaser; and

28.1.2) the aggregate liability of the supplier to the purchaser, whether under the contract, in tort or otherwise, shall not exceed the total contract price, provided that this limitation shall not apply to the cost of repairing or replacing defective equipment.

29. GOVERNING LANGUAGE

29.1) The contract shall be written in English. All correspondence and other documents pertaining to the contract that is exchanged by the parties shall also be written in English.

30. APPLICABLE LAW

30.1) The contract shall be interpreted in accordance with South African laws, unless otherwise specified.

31. NOTICES

31.1) Every written acceptance of a bid shall be posted to the supplier concerned by registered or certified mail and any other notice to him shall be posted by ordinary mail to the address furnished in his bid or to the address notified later by him in writing and such posting shall be deemed to be proper service of such notice

31.2) The time mentioned in the contract documents for performing any act after such aforesaid notice has been given, shall be reckoned from the date of posting of such notice.

32. TAXES AND DUTIES

- 32.1) A foreign supplier shall be entirely responsible for all taxes, stamp duties, license fees, and other such levies imposed outside the purchaser's country.
- 32.2) A local supplier shall be entirely responsible for all taxes, duties, license fees, etc., incurred until delivery of the contracted goods to the purchaser.
- 32.3) No contract shall be concluded with any bidder whose tax matters are not in order. Prior to the award of a bid SARS must have certified that the tax matters of the preferred bidder are in order.
- 32.4) No contract shall be concluded with any bidder whose municipal rates and taxes and municipal services charges are in arrears.

33. TRANSFER OF CONTRACTS

- 33.1) The contractor shall not abandon, transfer, cede, assign or sublet a contract or part thereof without the written permission of the purchaser.

34. AMENDMENT OF CONTRACTS

- 34.1) No agreement to amend or vary a contract or order or the conditions, stipulations or provisions thereof shall be valid and of any force unless such agreement to amend or vary is entered into in writing and signed by the contracting parties. Any waiver of the requirement that the agreement to amend or vary shall be in writing, shall also be in writing.

35. PROHIBITION OF RESTRICTIVE PRACTICES

- 35.1) In terms of section 4 (1) (b) (iii) of the Competition Act No. 89 of 1998, as amended, an agreement between, or concerted practice by, firms, or a decision by an association of firms, is prohibited if it is between parties in a horizontal relationship and if a bidder(s) is / are or a contractor(s) was / were involved in collusive bidding.
- 35.2) If a bidder(s) or contractor(s) based on reasonable grounds or evidence obtained by the purchaser has / have engaged in the restrictive practice referred to above, the purchaser may refer the matter to the Competition Commission for investigation and possible imposition of administrative penalties as contemplated in section 59 of the Competition Act No 89 Of 1998.
- 35.3) If a bidder(s) or contractor(s) has / have been found guilty by the Competition Commission of the restrictive practice referred to above, the purchaser may, in addition and without prejudice to any other remedy provided for, invalidate the bid(s) for such item(s) offered, and / or terminate the contract in whole or part, and / or restrict the bidder(s) or contractor(s) from conducting business with the public sector for a period not exceeding ten (10) years and / or claim damages from the bidder(s) or contractor(s) concerned.

MUNISIPALITEIT
VAN
PRINS ALBERT



MUNICIPALITY
OF
PRINCE ALBERT

PART B - BID SPECIFICATIONS AND PRICING SCHEDULE



PRINCE ALBERT MUNICIPALITY

Private Bag X53 / 33 Church Street

Prince Albert, 6930

Tel: 023 541 1668

Email: scm@pamun.gov.za

Fax: 023 541 1321

Website: www.pamun.gov.za

30 OCTOBER 2025

BID SPECIFICATIONS

RFQ 181 / 2025

APPOINTMENT OF A SPECIALISED SERVICE PROVIDER FOR THE ASSESSMENT , AND REPLACEMENT AND MAINTENANCE OF PUMPS AND MOTORS AT PRINCE ALBERT MUNICIPALITY'S WATER AND TREATMENT PLANTS AND PUMP STATIONS

1. INTRODUCTION

The existing Vertical Multi stage pumps at the Prince Albert Water Treatment Works have reached the end of their operational lifespan. Due to increasing maintenance cost, reduced efficiency, and the need for reliable water treatment processes, the decision has been made to replace these pumps. The upgrade is crucial to ensure the continued delivery of safe and clean water to the community.

2. COMPULSORY CLARIFICATION MEETING

2.1) A **compulsory** clarification meeting will be held as follow:

DATE: **10 November 2025**

VENUE: **Raw Water Reservoirs, Prince Albert, 6930**

GPS coordinates: 33.247064°S 22.037139°

DATE: **10 November 2025**

TIME: **10h00**

2.2) **No bids will be accepted from bidders who did not attend the compulsory clarification meeting. Any bidder arriving late at the clarification meeting will not be permitted to attend the clarification meeting.**

3. KEY OBJECTIVES

3.1) **Assesment of Existing pumps:**

To conduct throught out inspection, and compile a detailed Assessment and condition report on the findings and recommendations.

3.2) **Understanding Replacemnt Requirement:**

Discuss on site the specification and requirement for the new pumps, including capacity, efficiency and compatibilty with existing systems

3.3) **Timeline for Replacement:**

The project completion date is Friday 12 December 2025.

4. SCOPE OF WORK

4.1) Removal and Disposal of the existing Vertical multistage filters pumps to the Municipal depot

4.2) Supply of New Multistage Vertical filter pumps with motors that meet specified criteria.

4.3) Installation and commissioning of the new Vertical Multi stage Filter Pumps and motors.

4.4) Testing and validation of the new Vertical Multi stage Filter Pumps and motors to ensure they meet operational requirement.

4.5) Compile a site-specific Operations and Maintenance Manual in soft and hardcopy for both Vertical Multi stage filter pumps and motors

4.6) Provision of training for staff on the Operational and Maintenance of the new pumps and motors

4.7) Documentation of all work completed, including warranties.

5. PROJECT LOCATION AND SCOPE

WATER TREATMENT PLANT (WTW)	TECHNICAL DATA
Prince Albert WTW Vertical Munti stage Filter Pumps	<ul style="list-style-type: none">▪ Type: DL90-10-1▪ H= 14m▪ Q=90 m3/H▪ NPSH=3.0m▪ RPM=2900▪ KW=5.5▪ Serial Number:19112225008101

PERFORMANCE CURVES

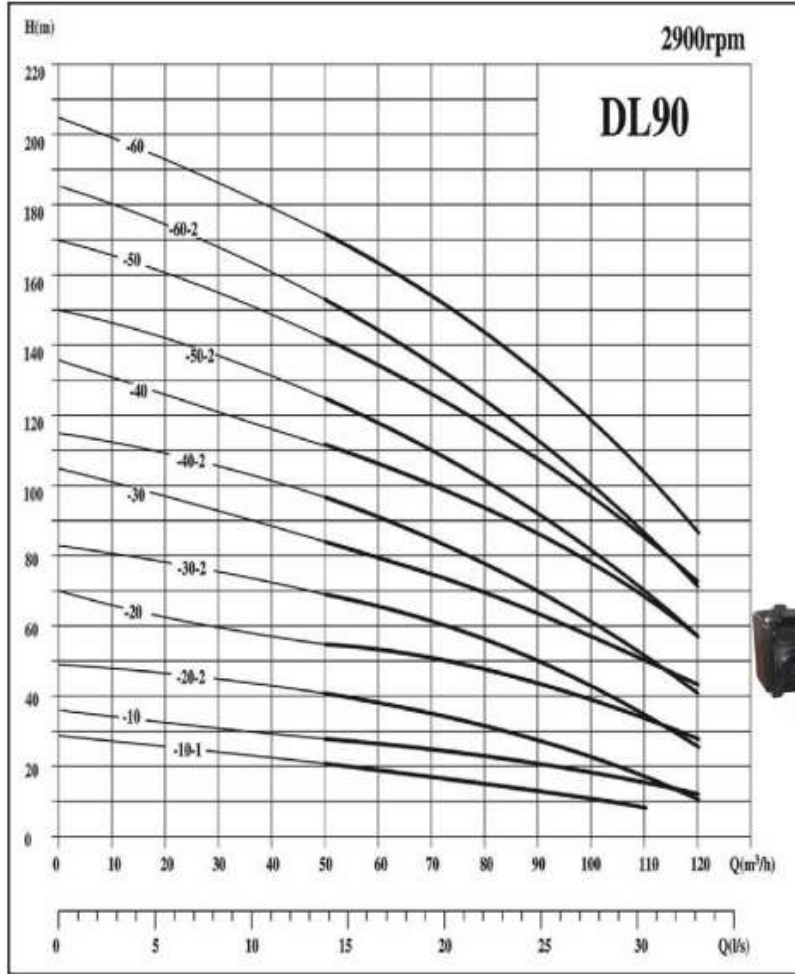

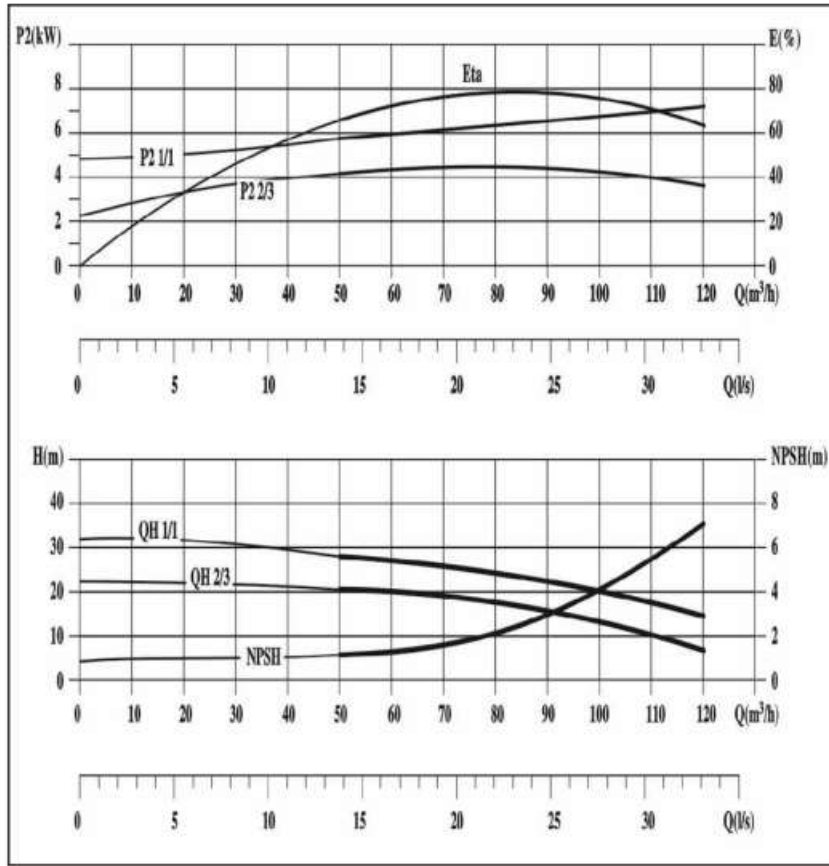

MODEL	POWER		CAPACITY									
	kW	HP	m³/h	50	60	70	80	90	100	110	120	
3 Phase 380V 50Hz			l/s	13.9	16.7	19.4	22.2	25	27.8	30.6	33.3	
DL90-10-1	5.5	7.5	Head (m)	20.5	19	17.5	15.5	14	10	8	7	
DL90-10	7.5	10		28	26.5	25	23.5	21	19	17.5	14.5	
DL90-20-2	11	15		41	38	34	31	28	20	17.5	11.5	
DL90-20	15	20		56	53	50	47	42	38	34	28	
DL90-30-2	18.5	25		69	65	59	54.5	48.5	40	35	26.5	
DL90-30	22	30		84	79.5	75	70.5	63	57	51	43.5	
DL90-40-2	30	40		97	91	84	78	70	58	51.5	41	
DL90-40	30	40		112	106	101	94	84	78	68	58	
DL90-50-2	37	50		125	117.5	109	101.5	91	77	68.5	56	
DL90-50	37	50		141	134	127	118	107	97	84	72	
DL90-60-2	45	60		153	144	135	125	112	100	85.5	69	
DL90-60	45	60		171	163	152	144	130	119	106	87	

PUMP DIMENSIONS

MODEL	DIMENSIONS (mm)						WEIGHT
	B1	B2	B1+B2	D1	D2	D3	
DL90-10-1	573	382	955	256	169	300	105
DL90-10	573	382	955	256	169	300	120
DL90-20-2	775	505	1280	330	260	350	123
DL90-20	775	505	1280	330	260	350	205
DL90-30-2	867	560	1427	330	260	350	210
DL90-30	867	590	1457	360	275	350	255
DL90-40-2	959	660	1619	400	305	400	320
DL90-40	959	660	1619	400	305	400	323
DL90-50-2	1051	660	1711	400	305	400	340
DL90-50	1051	660	1711	400	305	400	343
DL90-60-2	1143	710	1853	450	305	450	410
DL90-60	1143	710	1853	450	305	450	413

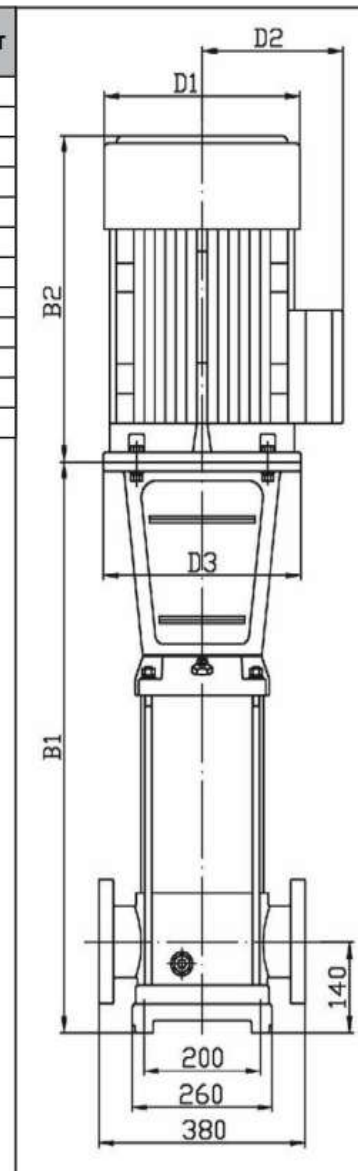
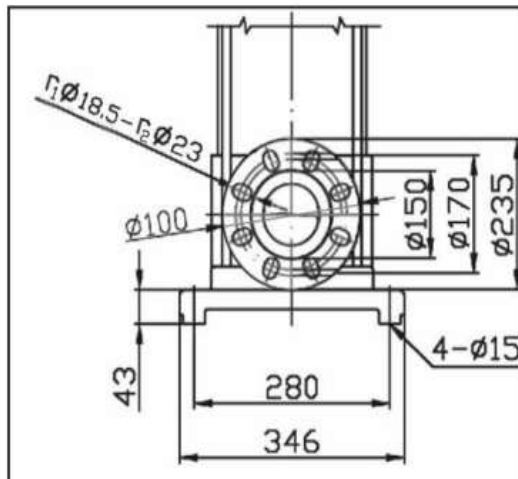

6. FUNCTIONALITY SCORING

This bid will be subject to functionality scoring. Bidders must obtain a minimum functionality score of **65 out of 100 points (65%)** in order for bids to be responsive. Bidders who do not comply, will be regarded as non-responsive.

CRITERIA	MAXIMUM POINTS
Technical qualifications of personnel to perform the replacement of pumps	35
Company experience to scope of works and reputation	65
TOTAL SCORE	100

6.1) Technical Qualification of personnel:

- Qualified Mechanical Engineering Technician
- Qualified Mechanical Artisan (Red Seal)
- Qualified Electrician (QCTO)

NUMBER OF STAFF WITH ABOVE QUALIFICATIONS	POINTS
Mechanical Engineering Technician NQF6/N6()	15
Mechanical Artisan (Millright) (Red Seal	10
Electrician (QCTO)	10
MAXIMUM POINTS AVAILABLE	35

NB:

- Certified copies of qualifications must be attached with the bid submission.
- Failure to comply (e.g., no attachments provided or copies is not certified, will result in zero points allocated for this section.

6.2) Company experience and reputation:

- Number of Vertical Multi stage Filter Pump replacement successfully completed previously:

NUMBER OF PROJECTS	POINTS
1 -2 Water Treatment Works Vertical Multi stage Filter Pumps replacement and servicing	20
3 - 4 Water Treatment Works Vertical Multi stage Filter Pumps replacement and servicing	50
>5 Water Treatment Works Vertical Multi stage Filter Pumps replacement and servicing	65
MAXIMUM POINTS	65

7. REGISTRATION AT THE CONSTRUCTION INDUSTRY DEVELOPMENT BOARD (CIDB)

Only those tenderers who are registered with the CIDB, in a contractor grading designation equal to or higher than a contractor grading designation determined in accordance with the sum tendered, or a value determined in accordance with Regulation 25 (1B) or 25 (7A) of the Construction Industry Development Regulations for a **1 ME** or higher class of grading are eligible to have their tenders evaluated

8. CONTACT PERSON (TECHNICAL / SPECIFICATION RELATED ENQUIRIES)

Mr. Selwyn Amsterdam (Superintendent: Water and Sanitation)

Tel: 023 541 1036

Cell: 081 011 5198

Email: selwyn@pamun.gov.za

MBD 3.1 – PRICING SCHEDULE

ITEM NR	DESCRIPTION	UOM	UNIT RATE (EXCL. VAT)	QTY	TOTAL PRICE (EXCL. VAT)
1.	0.0 – 5.5KW Vertical Multi stage filter pumps. Flow 100m3 10m head 80m3 at 15.5m head 120m3 at 7m	Nr		2	
2.	0.0 - 5.5KW Motor	Nr		2	
3.	Transportation (bidder to insert km quantity for return trip)	km		— —	
4.	Labour	Hrs		4	
SUBTOTAL (EXCL. VAT)					
VAT @ 15%					
BID AMOUNT (INCL. VAT) - (Carried forward to cover page)					

EVALUATION SCHEDULE- COMPANY EXPERIENCE AND REPUTATION

NAME OF EMPLOYER	CONTACT PERSON (NAME AND TEL, FAX, EMAIL)	NATURE OF WORK	VALUE OF WORK (INCLUSIVE OF VAT)	DATE STARTED

Attach additional pages if mores space is required.

Number of sheets appended by the tenderer to this schedule (If nil, enter NIL)	
--	--

Name of Bidder:

Signature:

Date:

MBD 7.2 - CONTRACT FORM – RENDERING OF SERVICES

THIS FORM MUST BE FILLED IN DUPLICATE BY BOTH THE SUCCESSFUL BIDDER (PART 1) AND THE PURCHASER (PART 2). BOTH FORMS MUST BE SIGNED IN THE ORIGINAL SO THAT THE SUCCESSFUL BIDDER AND THE PURCHASER WOULD BE IN POSSESSION OF ORIGINALLY SIGNED CONTRACTS FOR THEIR RESPECTIVE RECORDS.

PART 1 (TO BE FILLED IN BY THE BIDDER)

1. I hereby undertake to render services described in the attached bidding documents to **PRINCE ALBERT MUNICIPALITY** in accordance with the requirements and task directives / proposals specifications stipulated in Bid Number **RFQ 181 / 2025** at the price/s quoted. My offer/s remain binding upon me and open for acceptance by the Purchaser during the validity period indicated and calculated from the closing date of the bid.

2. The following documents shall be deemed to form and be read and construed as part of this agreement:
 - (i) Bidding documents, viz
 - Invitation to bid;
 - Tax Status Pin
 - Pricing schedule(s);
 - Technical Specification(s);
 - Preference claims for Broad Based Black Economic Empowerment Status Level of Contribution in terms of the Preferential Procurement Regulations 2022;
 - Declaration of interest;
 - Declaration of bidder’s past SCM practices;
 - Certificate of Independent Bid Determination;
 - Special Conditions of Contract;
 - (ii) General Conditions of Contract; and
 - (iii) Other (specify)

3. I confirm that I have satisfied myself as to the correctness and validity of my bid; that the price(s) and rate(s) quoted cover all the goods and/or works specified in the bidding documents; that the price(s) and rate(s) cover all my obligations and I accept that any mistakes regarding price(s) and rate(s) and calculations will be at my own risk.

4. I accept full responsibility for the proper execution and fulfilment of all obligations and conditions devolving on me under this agreement as the principal liable for the due fulfilment of this contract.

5. I declare that I have no participation in any collusive practices with any bidder or any other person regarding this or any other bid.

6. I confirm that I am duly authorised to sign this contract.

NAME (PRINT)

CAPACITY

SIGNATURE

NAME OF FIRM

DATE

WITNESSES
1.
2.
DATE: